

# WINEGARD® DS-2076 ASSEMBLY INSTRUCTIONS

---

**STEP 1.** Assemble the mount pipe and foot as shown in Figure 1.

**CAUTION:** Do Not Overtighten the 1/4-20 X 2-1/2" Bolt. May Crush Mount Pipe.

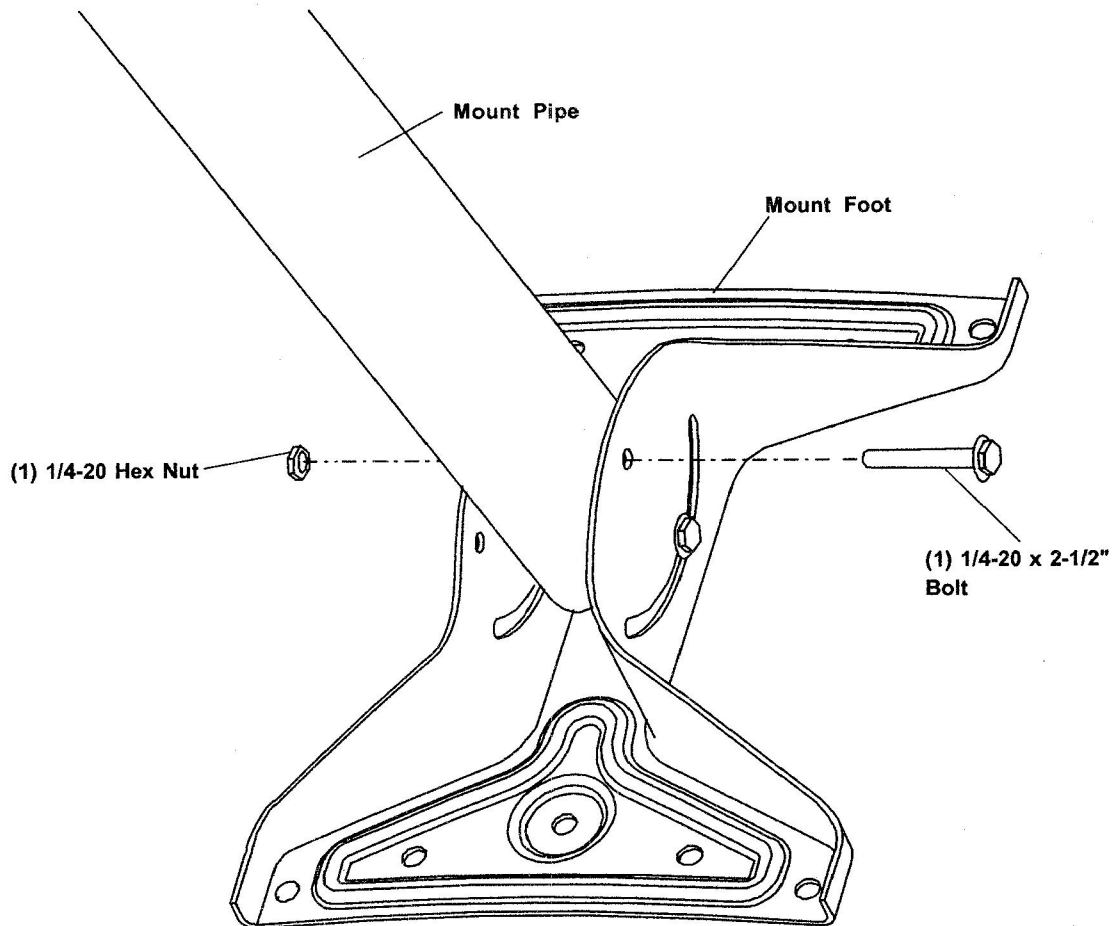

**FIGURE 1**

**STEP 2.** Attach the reflector and feed support to the backup as shown in Figure 2.

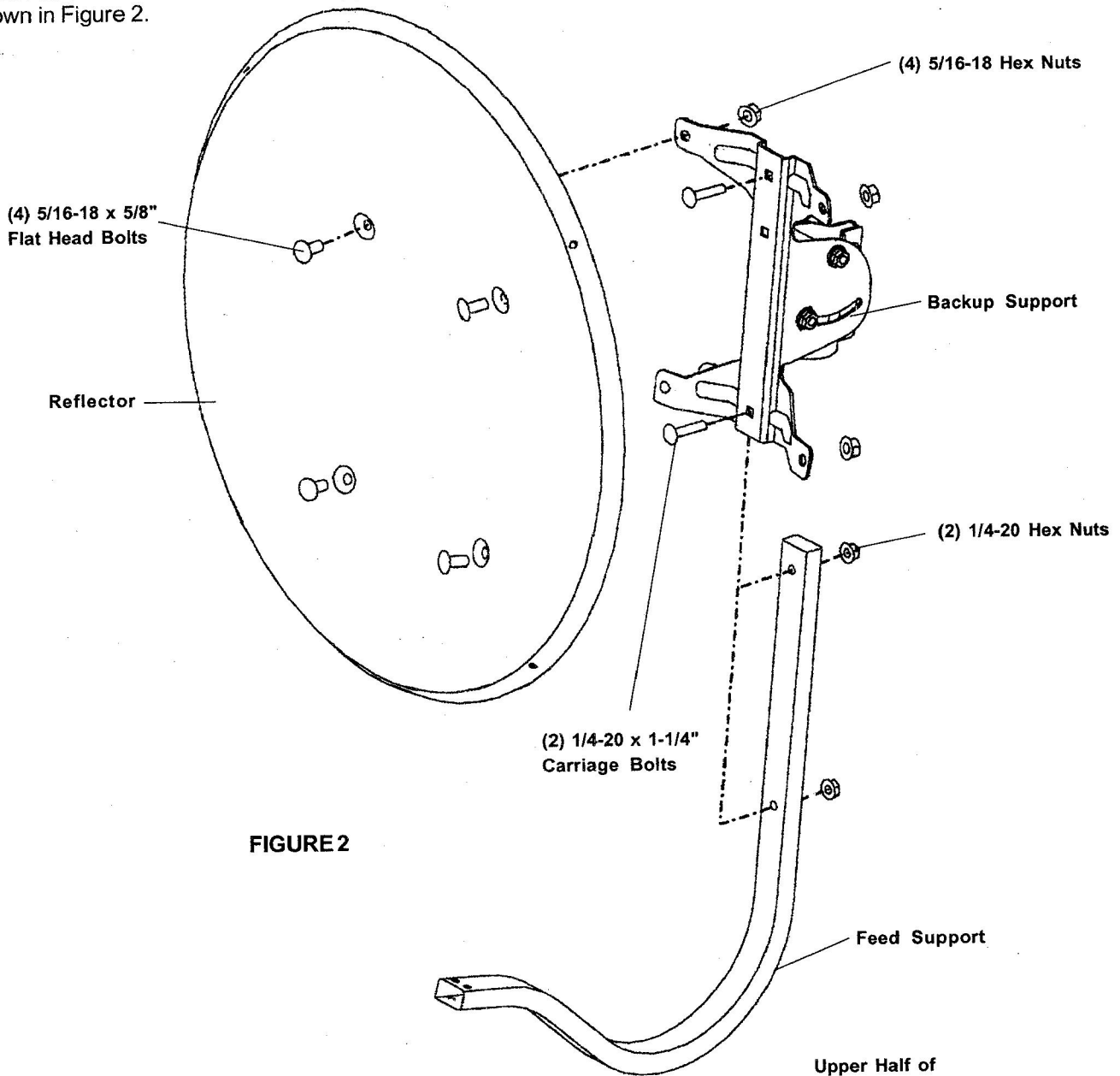

**FIGURE 2**

**STEP 3.** Attach feed clamp to feed support as shown in Figure 3.

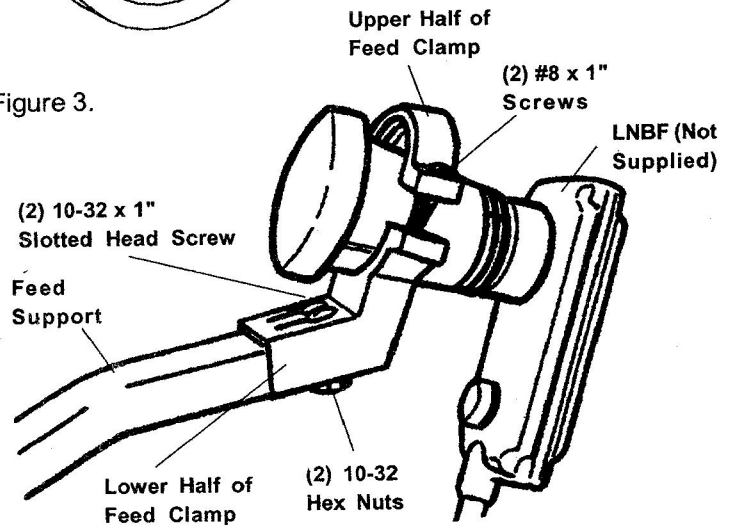

**FIGURE 3**