

**90cm, 1.0m & 1.2m SMC Antenna System
with Az/El Cap Mount**

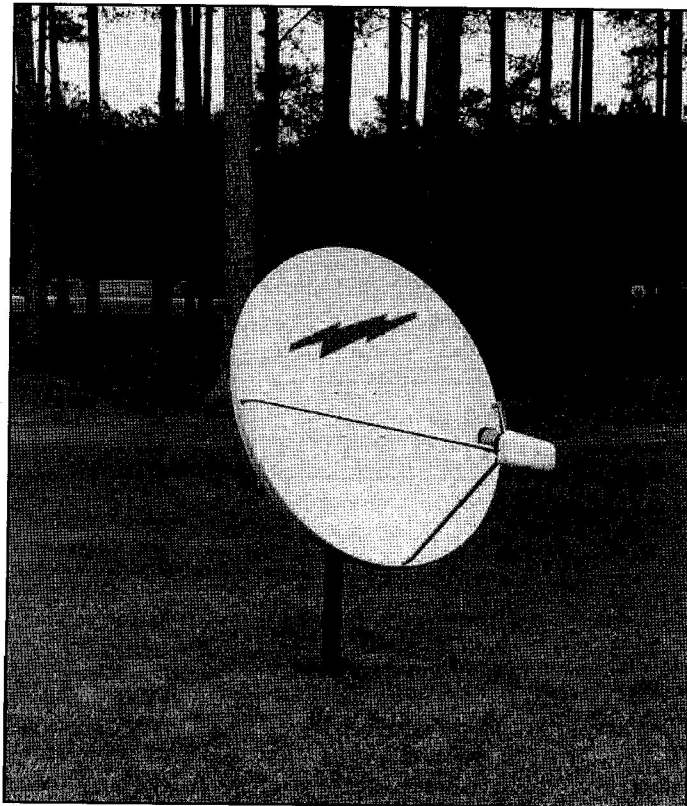

TYPE 900 - 90cm

TYPE 100 - 1.0m

TYPE 120 - 1.2m

SMC ANTENNA WITH AZ/EL CAP MOUNT

DATE	DESCRIPTION	REV.
2/26/90	Changed Pages 4, 6, 7, 8, 9 and 10. ECN 9001516	A
4/20/90	Changed Pages 3, 4, 5, 6, 7, 8, 9 & 10. ECN 9001550	B
9/10/90	Changed Cover, Pages 1, 6, 7, 12 & 13. ECN 9001616	C
11/19/90	Changed Cover, Pages 1, 3, 4, 5, 6, 7, 8, 0, 10, 11 & 13. ECN 9001665	D
11/4/91	Changed Cover, Pages 1, 2, 3, 4, 6 & 8-18. ECN 9001881	E
9/93	Changed Cover, Inside Front Cover, Pages 1, 4, 6, 7, 8, 9, 10 & 11. ECN 9002250	F
10/94	Changed Cover and Page 1. ECN 9002568	G
8/97	All Pages ECN 9003587	H
8/02	Changed Pages 4, 6, 10 & 12 ECN 9006120	J
9/02	Changed Pages 4, 6, & 10 ECN 9006205	K
8/04	ECN9006837	-
12/04	New Revised Warranty ECN 9006999	
9/05	ECN 9007200	

DANGER!!!

WATCH FOR WIRES! Installation of this product near power lines is dangerous. YOU CAN BE KILLED IF THIS PRODUCT COMES NEAR POWER LINES! For your own safety, follow these important safety rules.

1. Perform as many functions as possible on the ground.
2. Watch out for overhead power lines. Check the distance to the power lines before starting installation. We recommend you stay a minimum of 6 meters (20 feet) from all power lines.
3. Do not use metal ladders.
4. Do not install antenna or mast assembly on a windy day.
5. If you start to drop antenna or mast assembly, get away from it and let it fall.
6. If any part of the antenna or mast assembly comes in contact with a power line, call your local power company. **DO NOT TRY TO REMOVE IT YOURSELF!** They will remove it safely.
7. Make sure that the mast assembly is properly grounded.

WARNING!!!

Assembling dish antennas on windy days can be dangerous. Because of the antenna surface, even slight winds create strong forces. For example, a 1.0m antenna facing a wind of 32 km/h (20 mph) can undergo forces of 269 N (60 lbs). Be prepared to safely handle these forces at unexpected moments. Do not attempt to assemble, move or mount a dish on windy days or serious, even fatal accidents may occur. ANDREW is not responsible or liable for damage or injury resulting from antenna installations.

INTRODUCTION

This manual covers the installation of the ANDREW 1.0m & 1.2m SMC antenna system with AZ/EL cap mount and single polarity feed. For best results in the assembly process, perform each step in the same sequence as listed in this manual.

ASSEMBLY TOOLS REQUIRED

The following list of tools are those required for hand assembly and installation of the antenna.

- | | | |
|---------------------------------|--------------------------|------------------------------|
| 1 - Ratchet Wrench (3/8" Drive) | 1 - 10mm Nut Driver | 1 - 13mm Socket (3/8" Drive) |
| 1 - 13mm Open/Box End Wrench | 1 - Phillips Screwdriver | 1 - Compass |

SITE SELECTION

The first and most important consideration when choosing a prospective antenna site is whether or not the area can provide an acceptable "look angle" at the satellites. A site with a clear, unobstructed view from a suitable roof or wall facing south, southeast or southwest is required. Your antenna site must be selected in advance so that you will be able to receive the strongest signal available. To avoid obstructions, it is important to conduct an on-site survey with a portable antenna.

As with any type of construction, a local permit may be required before installing an antenna. It is the owner's responsibility to obtain any and all permits.

BOLT TORQUE

GRADE 8.8 (8G) - YELLOW COLOR						GRADE 2 - SILVER COLOR							
M6	M8	M10	M12	M16	M20	#10	1/4 IN.	5/16 IN.	3/8 IN.	1/2 IN.	5/8 IN.	3/4 IN.	1 IN.
7	18	32	58	144	260	32	6	11	20	43	92	124	259
FT-LBS	FT-LBS	FT-LBS	FT-LBS	FT-LBS	FT-LBS	FT-LBS	FT-LBS	FT-LBS	FT-LBS	FT-LBS	FT-LBS	FT-LBS	FT-LBS
9.5	24	43	79	195	353	3.6	8	15	27	58	125	168	351
N-m	N-m	N-m	N-m	N-m	N-m	N-m	N-m	N-m	N-m	N-m	N-m	N-m	N-m

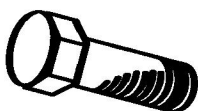

APPLY 24 N-m (18 FT-LBS) OF TORQUE TO M8 BOLT



APPLY 11 FT-LBS (15 N-m) OF TORQUE TO 5/16" BOLT

GROUND POLE INSTALLATION

2-3/8" O.D. x 72" LONG

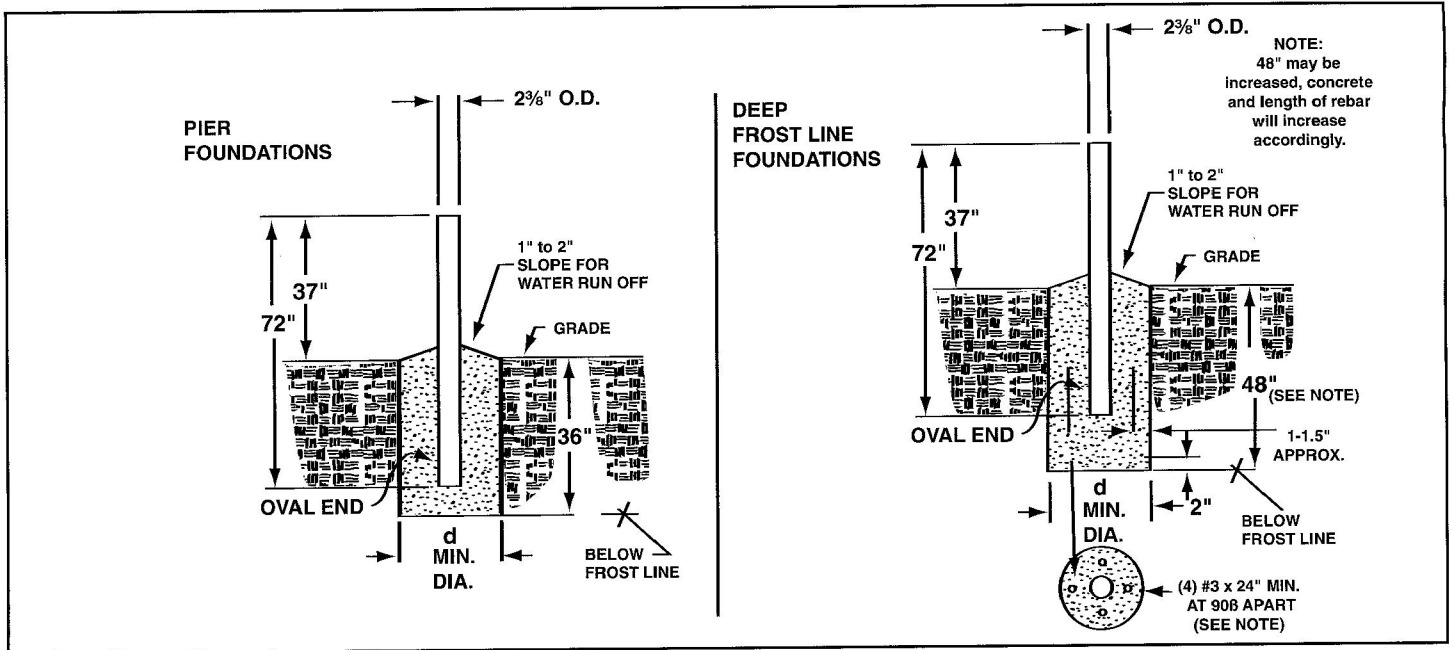

PIER FOUNDATIONS				DEEP FROST LINE FOUNDATIONS		
ANT	WIND VEL.	DIM "d"	CONC VOL.	DIM "d"	CONC VOL.	GROUND POLE
90cm	80 MPH	9"	1.5 FT ³	7"	1.2 FT ³	Mo. 611652931
	90 MPH	11"	2.2 FT ³	7"	1.2 FT ³	
	100 MPH	13"	3.0 FT ³	8"	1.5 FT ³	
	110 MPH	15"	4.0 FT ³	10"	2.4 FT ³	
	125 MPH	18"	5.8 FT ³	12"	3.5 FT ³	
1.0M	80 MPH	10"	1.8 FT ³	7"	1.2 FT ³	Mo. 611652931
	90 MPH	13"	3.0 FT ³	8"	1.5 FT ³	
	100 MPH	15"	4.0 FT ³	9"	1.9 FT ³	
	108 MPH	16"	4.6 FT ³	10"	2.4 FT ³	

GROUND POLE SPECIFICATIONS:

GROUND POLE = 2" SCH 40 2-3/8" O.D. x .154 Wall x 72" Long Steel w/Oval End and Powder Paint Finish.

- When wind velocity exceeds 108 MPH on the 90cm antenna at heights shown, the ground pole must be a heavy wall pipe as follows: 2" pipe (2 3/8" O.D.) Schedule 80 (.218" wall thickness) and purchased locally. Field weld 1/4" x 1 1/2" x 5 key as shown in Fig. 1.0 to prevent rotation in the concrete or use 3" O.D. ground pole and AZ/EL cap.
- These charted values based on using Model 611652931 ground pole, 2.375 O.D. x 1.54 wall. When wind velocity exceeds 108 MPH, use 3" O.D. ground pole and AZ/EL cap.
- Pole and foundation design based on the following criteria: (a) Uniform Building Code Exposure C and 1.5 stability factor, (b) Vertical soil pressure of 2000 pounds per square foot, (c) Lateral soil pressure of 400 pounds per square foot, (d) Concrete compressive strength of 2500 pounds per square inch in 28 days.
- CAUTION** - The foundation design shown does not represent an appropriate design for any specific locality since soil conditions vary and may not meet design criteria given in Note 1. You should consult a local professional engineer to determine your soil conditions and appropriate foundation.

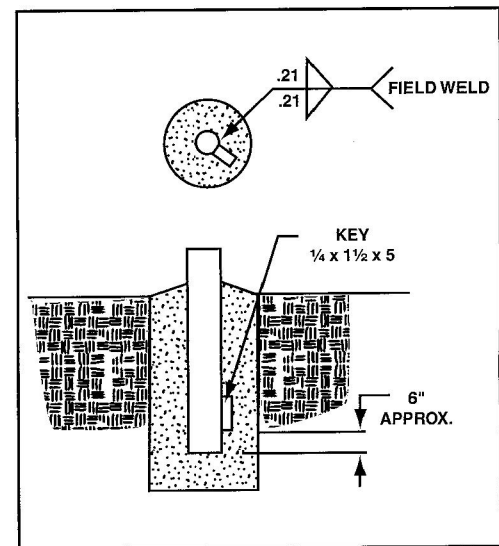
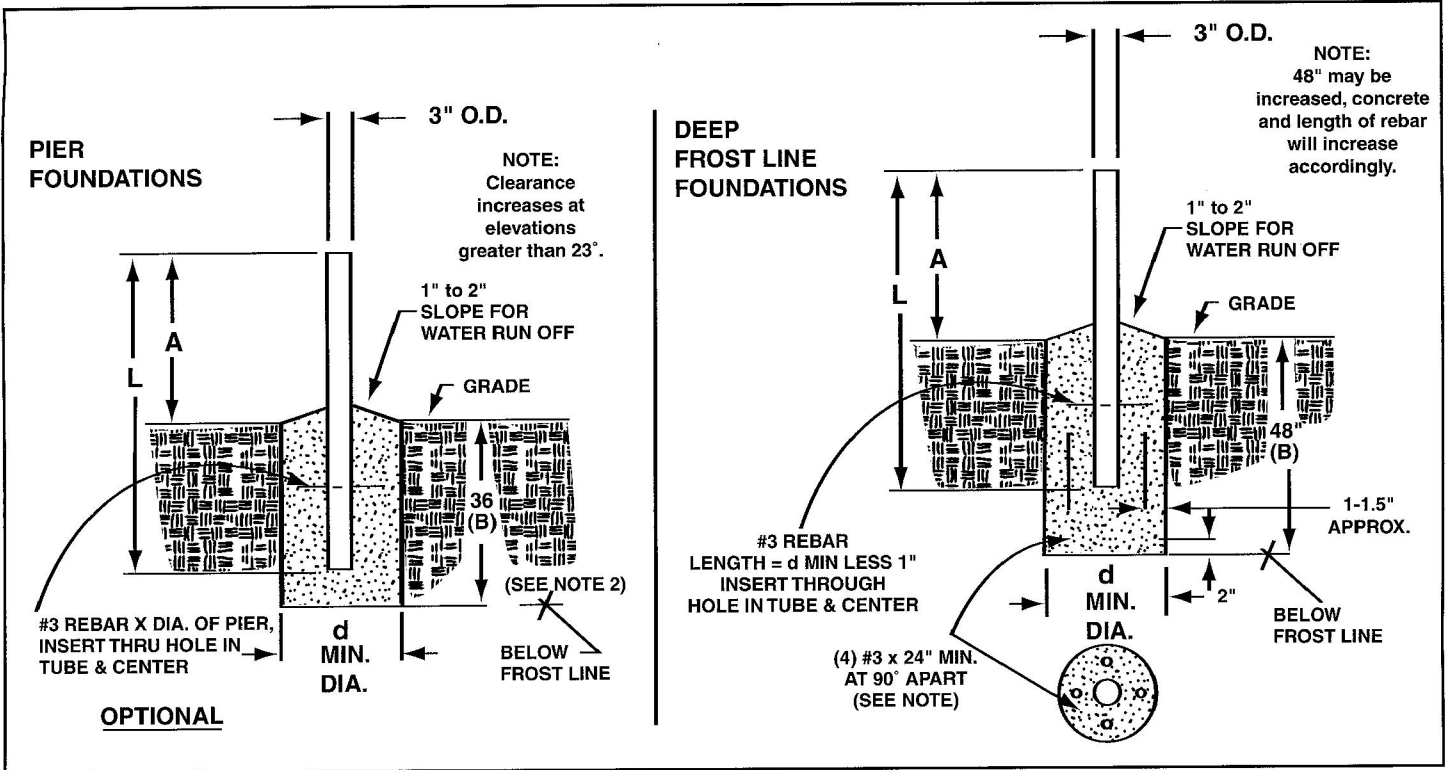

FIG. 1.0

GROUND POLE INSTALLATION

3" O.D. x 68" & 72" LONG



PIER FOUNDATIONS

DEEP FROST LINE FOUNDATIONS

ANT	WIND VEL.	DIM "L"	DIM "A"	DIM "d"	CONC VOL.	DIM "L"	DIM "A"	DIM "d"	CONC VOL.	GROUND POLE
90cm	80 MPH	68"	37"	9"	1.5 FT ³	68"	37"	7"	1.2 FT ³	Mo. 611652731 See Note 2
	90 MPH			11"	2.2 FT ³			7"	1.2 FT ³	
	110 MPH			13"	3.0 FT ³			8"	1.5 FT ³	
	110 MPH			15"	4.0 FT ³			10"	2.4 FT ³	
	125 MPH			18"	5.8 FT ³			12"	3.5 FT ³	
1.0M	80 MPH	68"	37"	10"	1.8 FT ³	68"	37"	7"	1.2 FT ³	Mo. 611652731 See Note 2
	90 MPH			13"	3.0 FT ³			8"	1.5 FT ³	
	110 MPH			15"	4.0 FT ³			10"	2.4 FT ³	
	110 MPH			17"	5.2 FT ³			11"	2.9 FT ³	
	125 MPH			20"	7.2 FT ³			14"	4.7 FT ³	
1.2M	80 MPH	72"	39"	14"	3.5 FT ³	72"	39"	9"	1.9 FT ³	Mo. 611685101 See Note 2
	90 MPH			17"	5.2 FT ³			11"	2.9 FT ³	
	110 MPH			19"	6.5 FT ³			13"	4.1 FT ³	
	110 MPH			22"	8.7 FT ³			15"	5.4 FT ³	
	125 MPH			25"	11.2 FT ³			19"	8.7 FT ³	

POLE SPECIFICATIONS:

3" O.D. x .120 Wall x 68" Long Steel w/Powder Paint Finish

3" O.D. x .148 Wall x 72" Long Steel w/Powder Paint Finish

1. Pole and foundation design based on the following criteria: (a) Uniform Building Code Exposure C and 1.5 stability factor, (b) Vertical soil pressure of 2000 pounds per square foot, (c) Lateral soil pressure of 400 pounds per square foot, (d) Concrete compressive strength of 2500 pounds per square inch in 28 days.
2. If Model 6851 (3" x 72") is used for 90cm and 1.0m Antenna Dimension "B" on pier foundation must be increased by 4" and concrete volume will increase accordingly.
3. **CAUTION** - The foundation design shown does not represent an appropriate design for any specific locality since soil conditions vary and may not meet design criteria given in Note 1. You should consult a local professional engineer to determine your soil conditions and appropriate foundation.

ASSEMBLY AND INSTALLATION

The AZ/EL Cap Mount can be installed on a 2 3/8" or 3" O.D. ground tube, roof, or wall mount depending on model. The appropriate mount should be assembled and in place before installing the AZ/EL cap.

As the AZ/EL cap mount is factory preassembled, there is no assembly required for the mount.

ASSEMBLING ANTENNA TO CAP MOUNT

Install four M8 x 60mm (2 3/8") carriage bolts (1) into holes in center of reflector and assemble to cap mount flanges. (Reference Fig. 2.0) Install four lock washers (2) and hex nuts (3) on bolts. Tighten and torque to 11 ft.-lbs (15 N-m).

IMPORTANT! Bottom feed leg hole to be located as shown in Fig. 2.0.

INSTALLING CAP MOUNT ON MOUNT TUBE

Lift reflector/cap mount assembly and slide cap mount onto mount tube (Reference Fig. 2.1). Swivel antenna assembly until reflector faces southward.

Tighten M8 clamp nuts so that the antenna assembly is held stationary on tube, but can be swiveled with slight pressure.

FEED AND FEED LEGS INSTALLATION

Assemble feed assembly and feed legs to antenna as shown in Fig. 2.2.

Insert bottom feed leg (4) into hole in bottom edge of antenna (5). NOTE: Bottom feed leg is the one with a slight bend on one end of leg, lance on opposite end, and is shorter than the two side legs (6).

Install side legs (6) to antenna. From back side of antenna, secure with M6 x 30mm (1/4" x 1 3/16") hex bolts and 1/4" special (7/8" O.D.) flat washer (7 & 8). Do not tighten.

Insert bottom leg (4) into hole on center of junction block* (9) until lance on leg is engaged.

Insert one side leg (6) into junction block* (9) and secure with M6 x 30mm (1/4" x 1 3/16") hex bolts and 1/4" flat washer (7 & 10). Do not tighten.

Insert opposite side leg (6) into junction block* (9) and secure with M6 x 30mm hex bolt and 1/4" flat washer (7 & 10). **Tighten and torque bolts securing side legs to junction block and antenna to 4 ft.-lbs (5.4 N-m).**

Tighten self tapping screw (31) with bottom feed leg (make sure screw engages hole in leg).

Refer to feed instructions packed with feed to assemble and install the feed assembly.

*NOTE: Junction block (9) is packed with feed assembly.

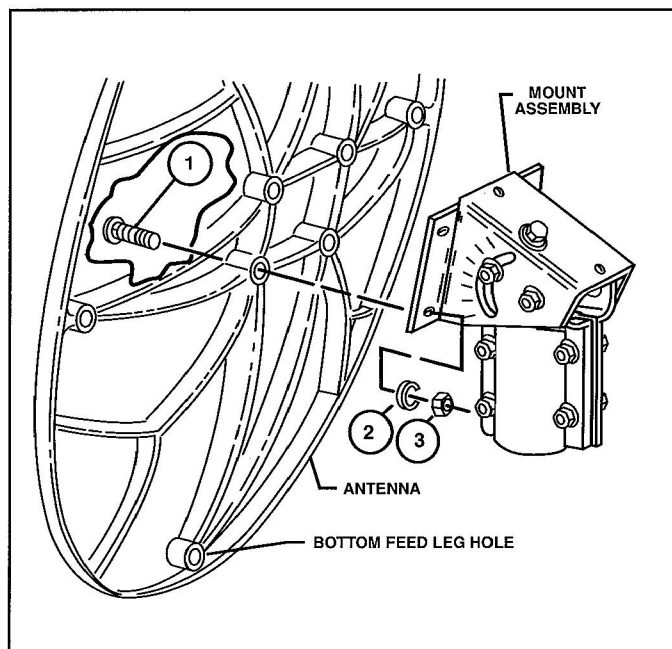

FIG. 2.0 - ASSEMBLING REFLECTOR TO AZ/EL CAP MOUNT

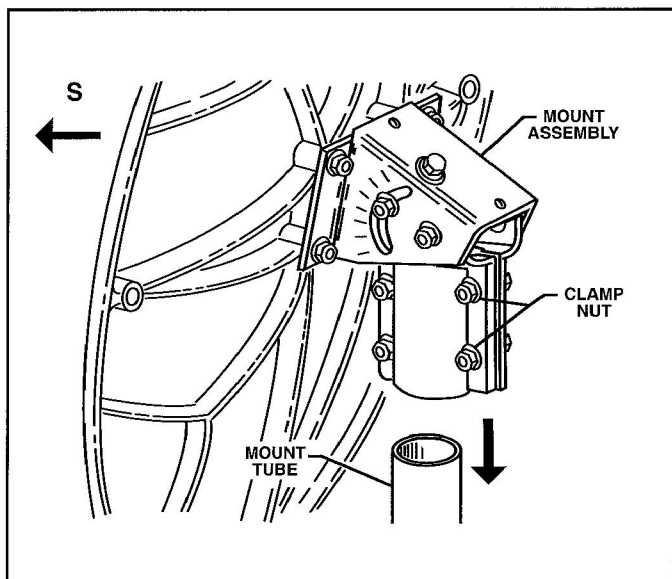

FIG. 2.1 - INSTALLING ANTENNA/MOUNT ASSEMBLY ONTO MOUNT TUBE

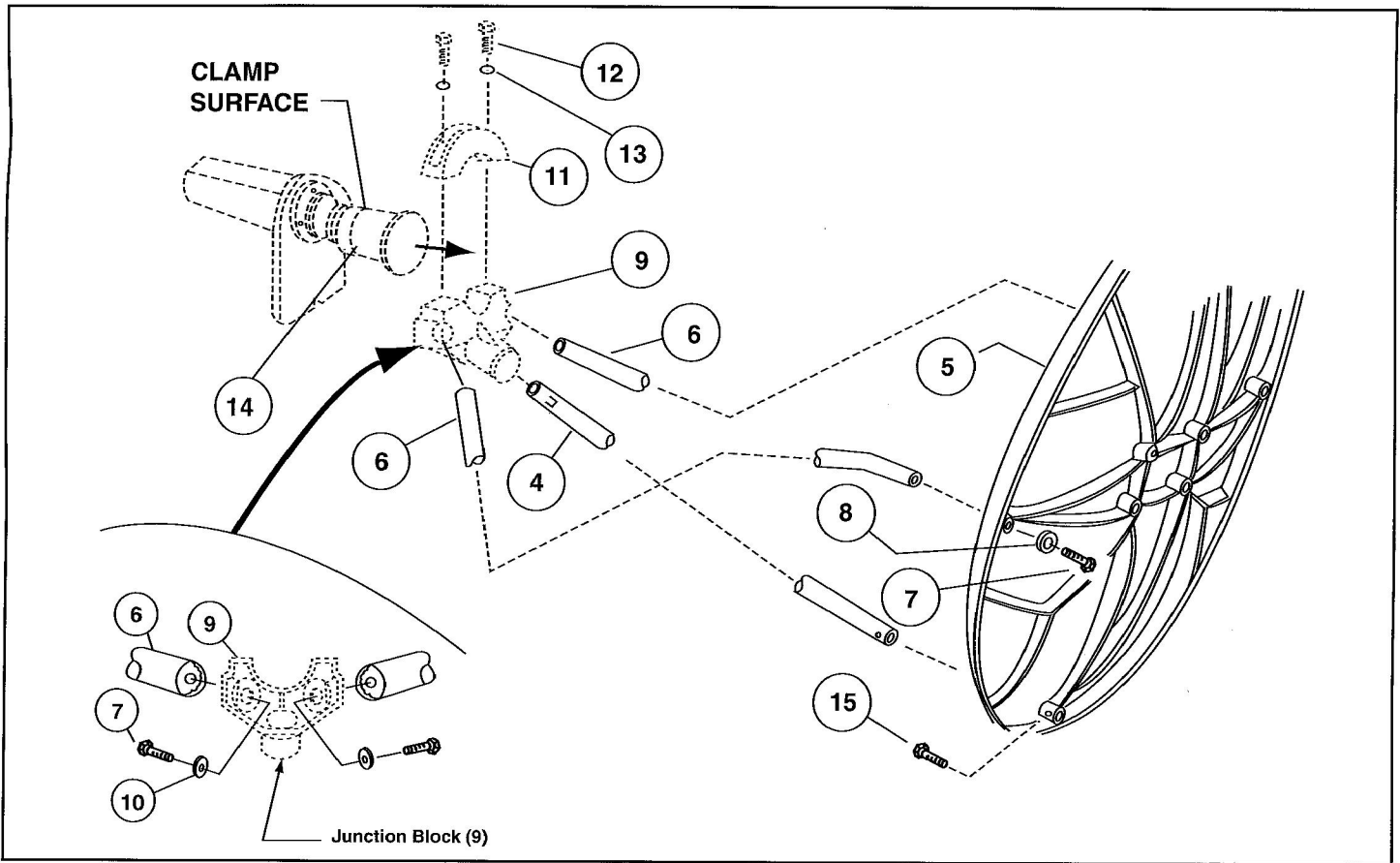

FIG. 2.2 - INSTALLATION OF FEED AND FEED SUPPORT LEGS TO ANTENNA

IMPORTANT: Sealing RF coaxial connector:

The copper-plated center conductor in the RF coaxial cable, which connects receiver to LNB, can experience electrolysis corrosion at the LNB connector. Moisture and DC current cause this type of corrosion. To prevent corrosion, apply a moderate coat of silicon grease to the center conductor and then wrap the entire connection with **COAX-SEAL®** tape to seal.

(COAX-SEAL® IS A REGISTERED TRADEMARK OF UNIVERSAL ELECTRONICS, INC.)

GROUNDING

ALL INSTALLATIONS TO CONFORM TO THE LATEST ISSUE OF THE NATIONAL ELECTRIC CODE.

Ground pole, antenna mount assembly and feed cables must be grounded in accordance with current National Electric Code and local electric codes to protect from surges due to nearby lightning strikes. The illustration below illustrates a typical grounding method.

Clamps that provide a solid connection between ground wire and ground source should be used.

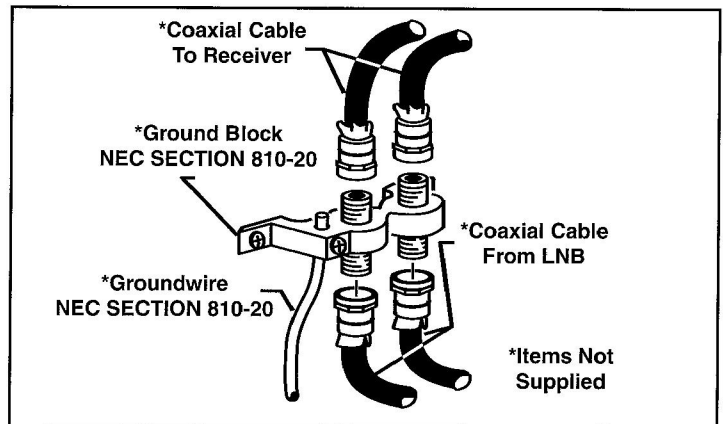

FIG. 2.3 - GROUNDING FEED CABLES

ANTENNA ALIGNMENT PROCEDURE

Alignment with the satellite is obtained by setting polarization, elevation and azimuth. Charts 1, 2 & 3 are to determine the values for your earth station antenna site. "ΔL" is the difference between the earth station antenna site longitude and the satellite longitude. Use "ΔL" and your earth station latitude to obtain polarization, elevation or azimuth setting.

POLARIZATION OF FEED

Loosen feed horn M6 clamp bolts (12) and turn feed clockwise or counterclockwise, depending on being east or west of the satellite as shown on Chart 1. Align marks on the horn clamp and appropriate mark on the horn scale clamp is installed with arrow pointed toward antenna as shown in Fig. 3.0. Keep cable groove on header in the down position when adjusting polarization. **NOTE: Single Polarity Feed is factory assembled for vertical polarity. If horizontal polarity is desired, rotate feed 90° (clockwise or counterclockwise).**

ELEVATION

To obtain elevation value for your satellite, refer to chart 2. Loosen bolts in curved slots of AZ/EL Housing 1/8 to 1/4 a turn (Ref. Fig. 3.1). Turn elevation adjustment bolt clockwise to decrease elevation and counterclockwise to increase elevation. Align the edge of clamp with appropriate mark at the desired elevation reading (Ref. Fig. 3.1). **NOTE: Degree values shown on elevation scale are Beam; that is when the antenna face is vertical mechanical elevation is 0°, while the Beam Elevation (signal) is 22.6°.** This will be an approximate setting. Optimum setting achieved when fine tuning. Temporarily tighten elevation bracket nuts.

AZIMUTH

Use Chart 3 and determine your azimuth setting. Values in chart must be adjusted for magnetic deviation for your location for correct compass reading. Rotate the antenna and mount, pointing it to the correct compass reading for your location and satellite (Ref. Fig. 3.2). Slowly sweep the antenna in azimuth until a signal is found. If the desired signal is not found, increase or decrease elevation setting and repeat the azimuth sweep.

FINE TUNING

Use a signal strength measuring device for final adjustments to obtain maximum antenna performance. Alternate between elevation and azimuth fine tuning to reach maximum signal strength until no improvement can be detected. Tighten all hardware. Torque for M8 round head, square neck bolts is 15 N-m (11 ft-lbs).

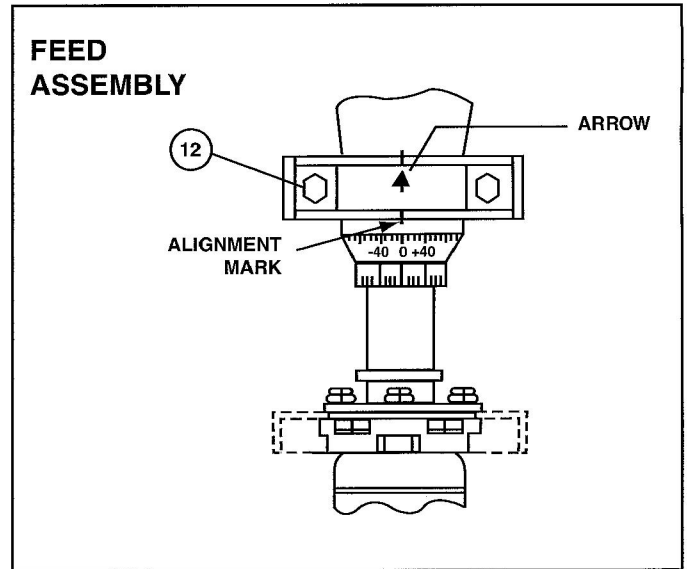

FIG. 3.0 - POLARIZATION OF THE FEED

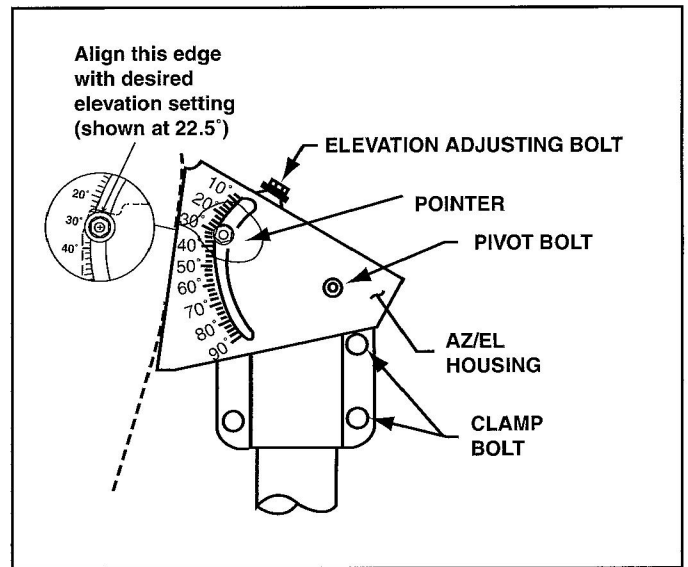

FIG. 3.1 - SETTING ANTENNA ELEVATION

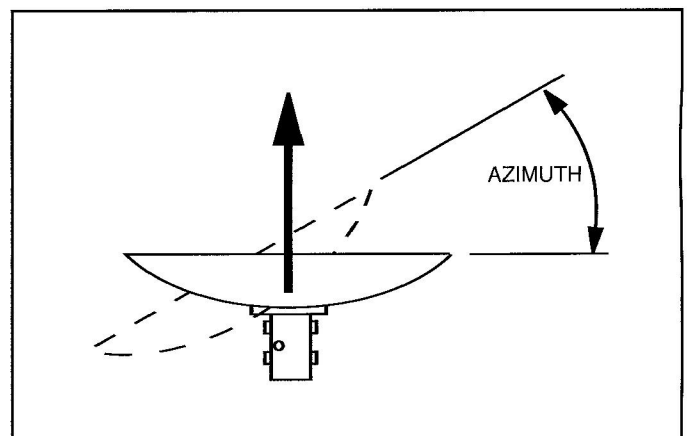
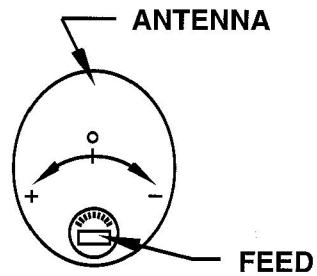

FIG. 3.2 - ROTATING ANTENNA FOR AZIMUTH

POLARIZATION CHART

"Δ L" IS THE DIFFERENCE BETWEEN THE EARTH STATION
ANTENNA SITE LONGITUDE AND THE SATELLITE LONGITUDE

POLARIZATION CHART SIGN VALUES (+ OR -)	NORTHERN HEMISPHERE	SOUTHERN HEMISPHERE
ANTENNA SITE WEST OF SATELLITE LONGITUDE	-	+
ANTENNA SITE EAST OF SATELLITE LONGITUDE	+	-



Feed Rotation (Facing Antenna)

For + Polarization, Rotate CCW (Counter Clockwise)
For - Polarization, Rotate CW (Clockwise)

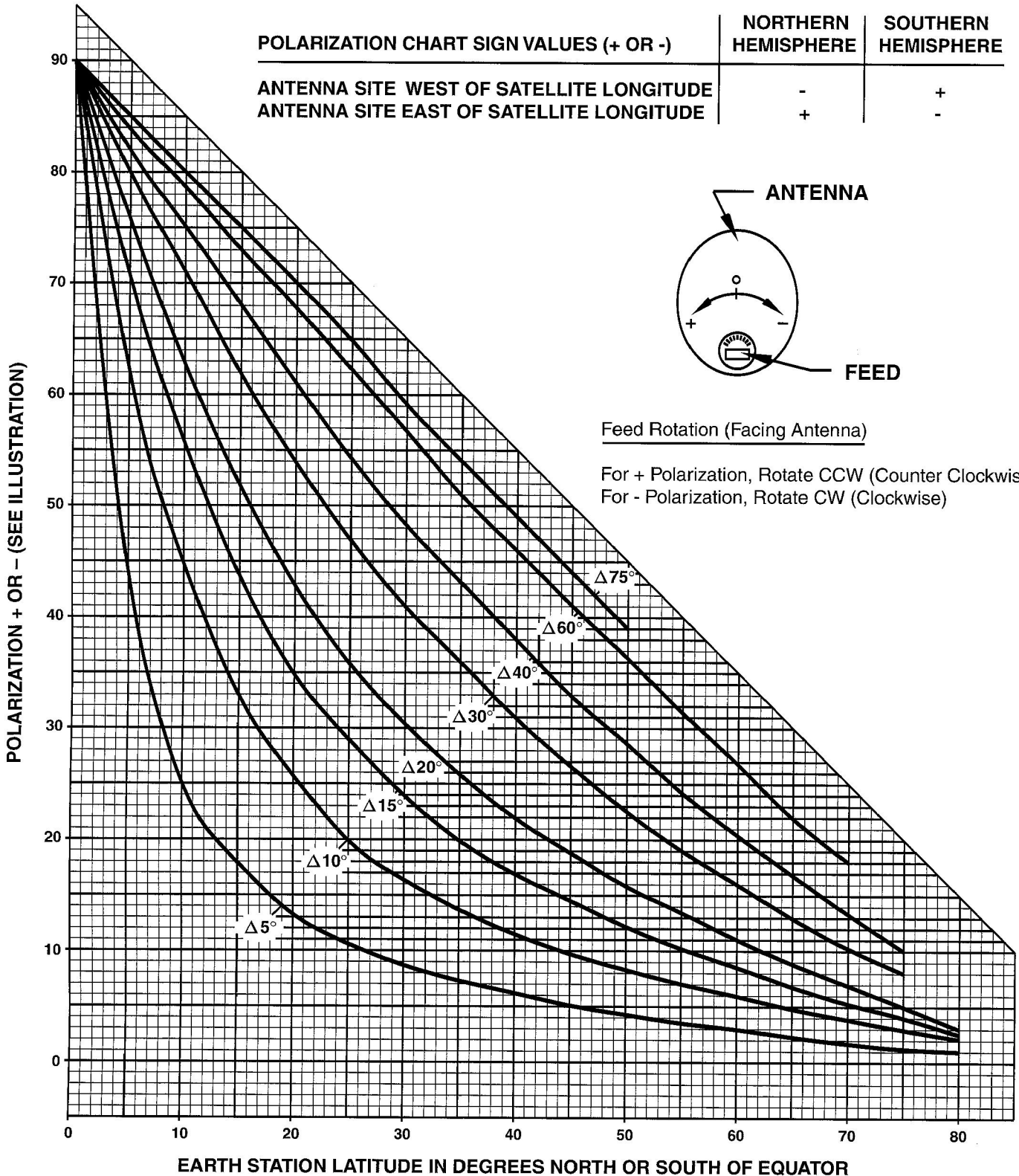

CHART 1

ELEVATION CHART

" ΔL " IS THE DIFFERENCE BETWEEN THE EARTH STATION ANTENNA SITE LONGITUDE AND THE SATELLITE LONGITUDE

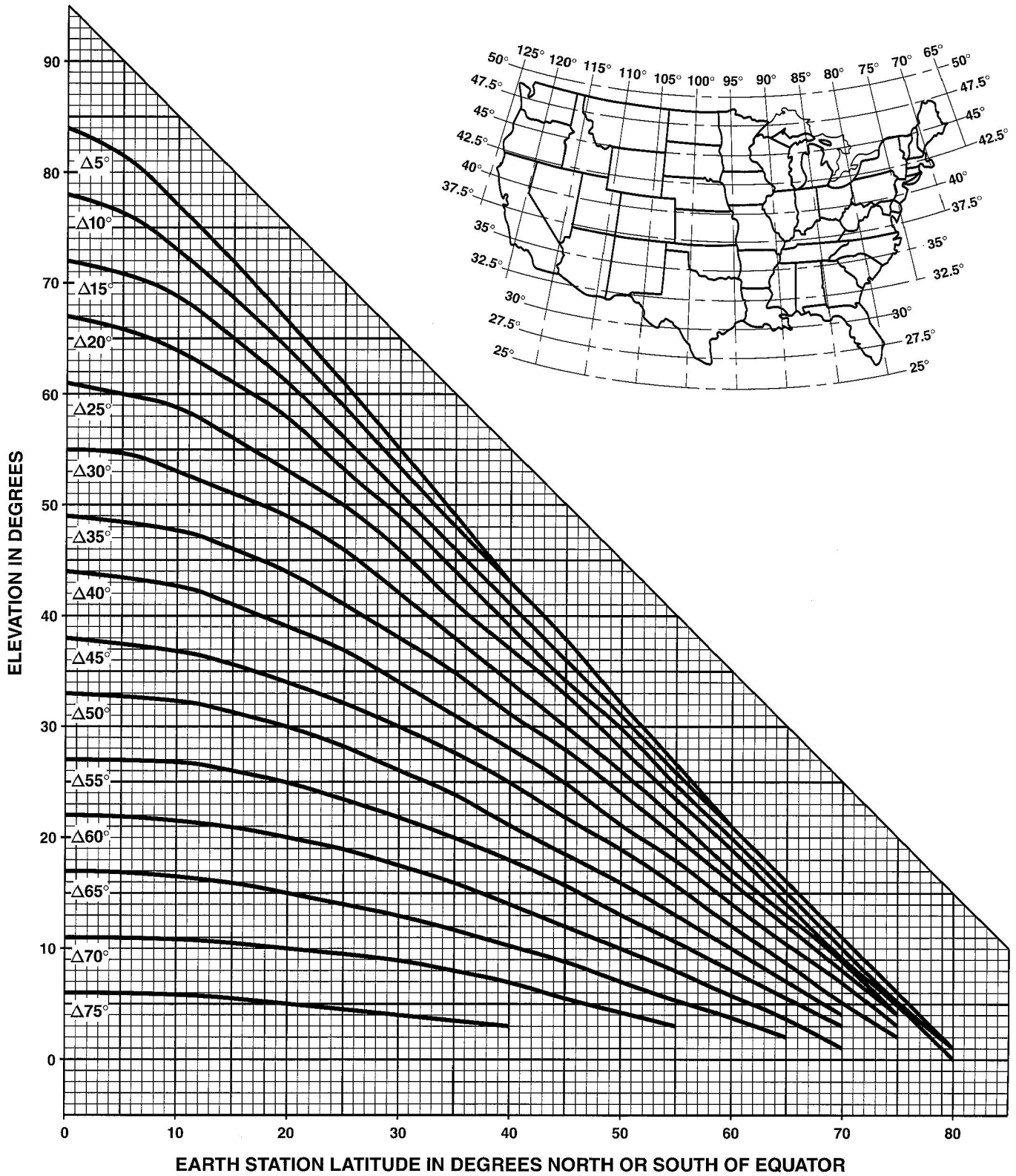

CHART 2

AZIMUTH CHART

"Δ L" IS THE DIFFERENCE BETWEEN THE EARTH STATION ANTENNA SITE LONGITUDE AND THE SATELLITE LONGITUDE

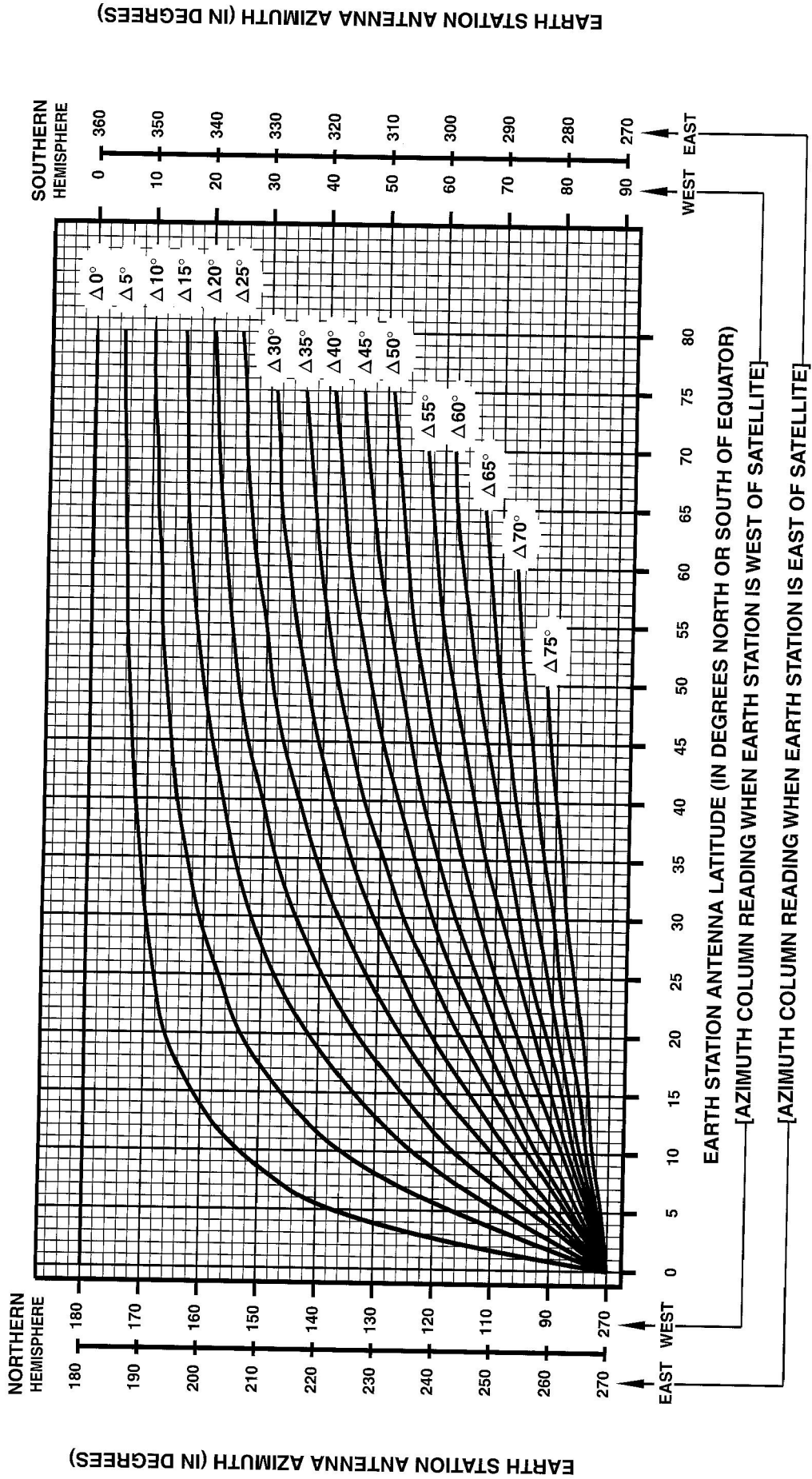

CHART 3

PARTS AND HARDWARE LISTING

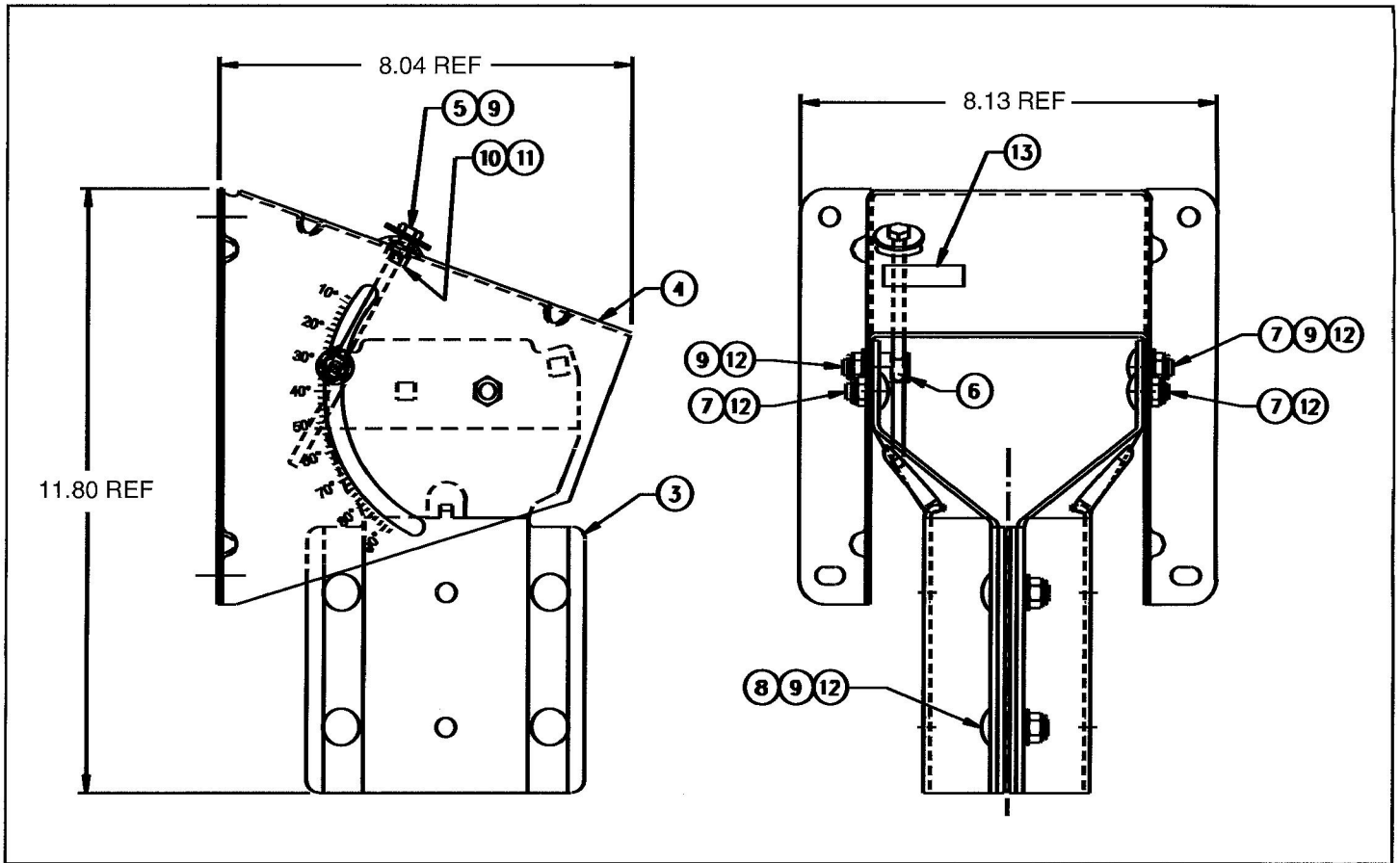

FIG. 4.0 - AZ/EL CAP MOUNT

ITEM	DESCRIPTION	QTY.
1	MOUNT ASSY AZ-EL CAP 2 7/8"-3" MAST	1
3	CLAMP HALF 2 7/8"-3" AZ-EL	2
4	HOUSING AZ-EL CAP MOUNT	1
5	BOLT, M8 x 130mm HEX HEAD	1
6	NUT, SWIVEL, SPECIAL M8	1
7	BOLT, M8 x 20mm, CRG	3
8	BOLT, M8 x 30mm, CRG	4
9	WASHER, 5/16" FLAT	7
10	NUT, M8, HEX	1
11	WASHER, SPHER., DELRIN	1
12	NUT, M8 ELASTIC STOP (ESNA)	8
13	LABEL, ELEVATION ADJUSTMENT	1

PARTS AND HARDWARE LISTING

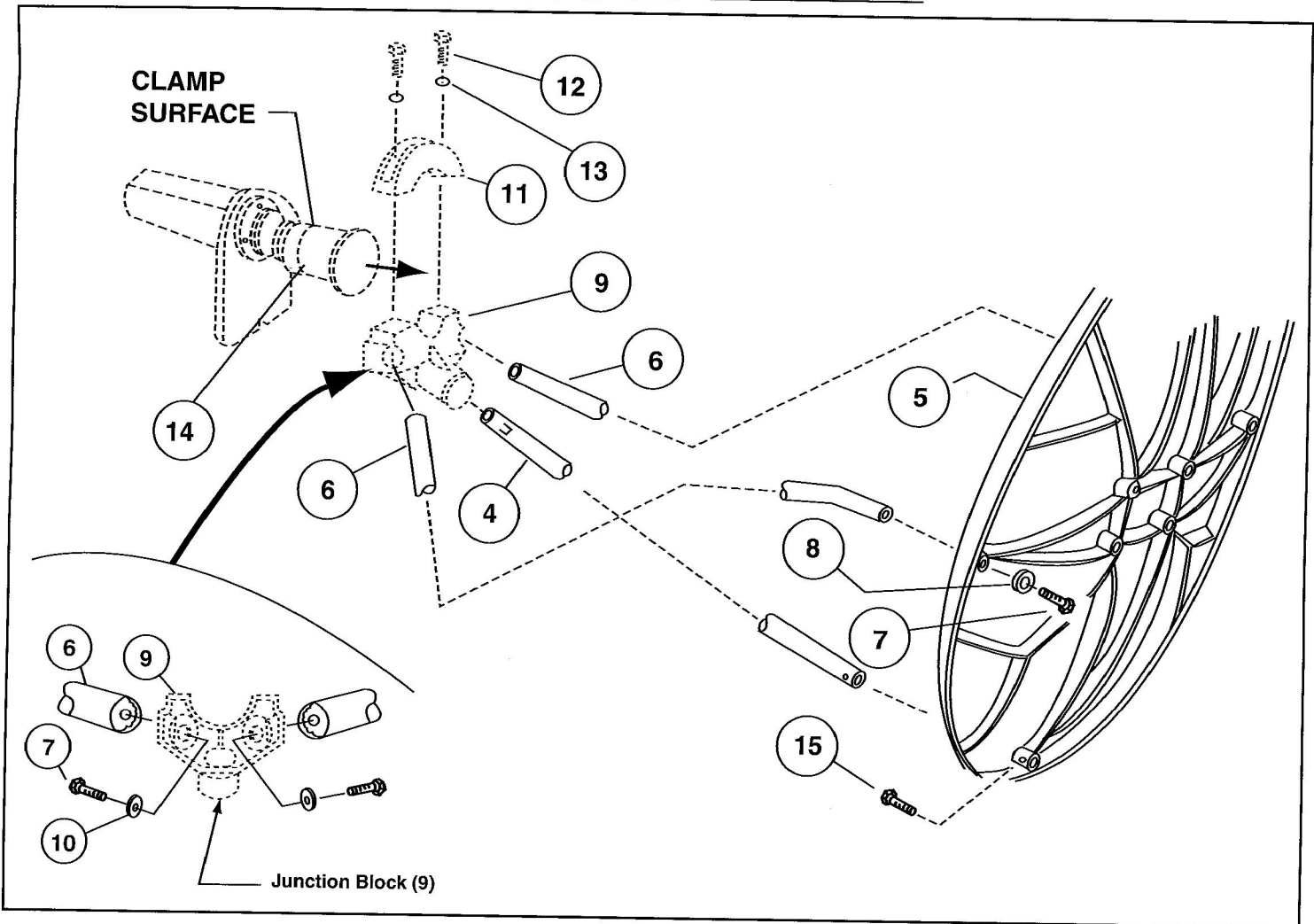
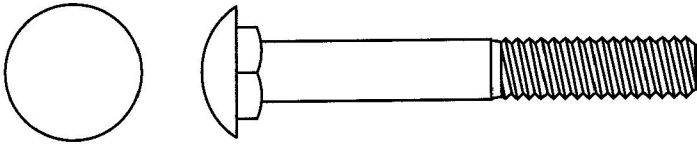

FIG. 4.1 - ANTENNA, ANTENNA FEED (LNB) & FEED SUPPORT LEGS

ITEM	DESCRIPTION	QTY.
4	LEG BOTTOM (90cm)	1
4	LEG-BOTTOM-FEED (1.0m)	1
4	LEG-BOTTOM-FEED (1.2m)	1
5	REFLECTOR-SMC 1.0m	1
5	REFLECTOR-SMC 1.2m	1
5	REFLECTOR-SMC 90cm	1
6	LEG-SIDE-FEED (1.0m)	2
6	LEG-SIDE-FEED (1.2m)	2
6	LEG-SIDE-FEED (90cm)	2
7	BOLT-HEX M6 x 30	4
8	WASHER, FLAT 1/4" x 7/8"	2
9*	BLOCK-JUNCTION	1
10	WASHER-FLAT 1/4" x 3/4" O.D.	2
11*	CLAMP-HALF-JCT.	1
12*	BOLT HH M6 x 20	2
13*	WASHER-FLAT M6 x 1/2" O.D.	2
14*	KU-FEED ASSY.	1
15	SCREW-TPG-SPL M6	1

*Provided in feed assembly.

HARDWARE SORTER



M8 x 60mm Round Head Square Neck Bolt

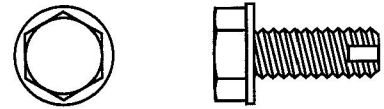

M6 Tapping Screw

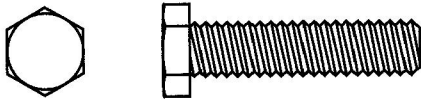

M6 x 30mm Hex Head Bolt

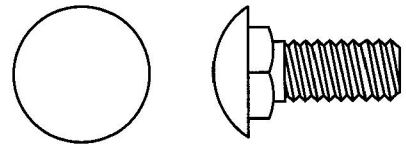

M8 x 20mm Round Head Square Neck Bolt



M4 x 12mm Phillips Head Screw

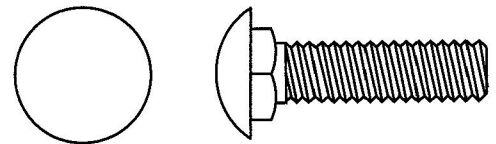

M8 x 30mm Round Head Square Neck Bolt



M4 x 10mm Phillips Head Screw

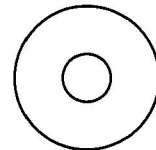

Washer, Flat - 1/4" x 3/4" OD

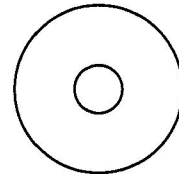

Washer, Flat - 1/4" x 7/8" OD

Hardware illustrations are true size.
Place actual hardware on top of illustration to identify.

ANDREW CORPORATION
VERY SMALL APERTURE TERMINAL (VSAT) PRODUCTS
TWELVE (12) MONTH LIMITED WARRANTY

Seller warrants that all Andrew manufactured VSAT products are transferred rightfully and with good title; that they are free from any lawful security interest or other lien or encumbrance unknown to Buyer. Seller also warrants that for a period of twelve (12) months from the date of shipment from Seller's factory, all its VSAT products shall be free from defects in material and workmanship which arise under proper and normal use and service. Buyer's exclusive remedy hereunder is limited to Seller's correction (either at its plant or at such other place as may be agreed upon between Seller and Buyer) of any such defects by repair or replacement at no cost to Buyer, except for the costs of any transportation in connection with the return of the defective VSAT products to be replaced or repaired, and the costs to remove and/or reinstall the products, which shall be borne by Buyer. The limited warranty period shall not be extended beyond its original term with respect to any part or parts repaired or replaced by seller hereunder.

This warranty shall not apply to VSAT products which (i) have been repaired or altered in any way so as to affect stability or durability, (ii) have been subject to misuse, negligence or accident, (iii) have been damaged by severe weather conditions such as excessive wind, ice, storms, lightning, or other natural occurrences beyond Seller's control; (iv) have presented damages, defects or nonconformances caused by improper shipping, handling or storage, and (v) have not been installed, operated or maintained in accordance with Seller's instructions.

Buyer shall present any claims along with the defective VSAT product(s) to Seller immediately upon failure. Non-compliance with any part of this warranty procedure may invalidate this warranty in whole or in part.

SELLER MAKES NOW WARRANTY, EXPRESS OR IMPLIED, OTHER THAN AS SPECIFICALLY STATED ABOVE. EXPRESSLY EXCLUDED ARE ANY IMPLIED WARRANTIES OF MERCHANTABILITY OR FITNESS FOR A PARTICULAR PURPOSE. THE FOREGOING SHALL CONSTITUTE ALL OF SELLER'S LIABILITY (EXCEPT AS TO PATENT INFRINGEMENT) WITH RESPECT TO THE VSAT PRODUCTS. IN NO EVENT SHALL SELLER BE LIABLE FOR ANY LOSS OF PROFITS OR REVENUE, LOSS OF USE, INTERRUPTION OF BUSINESS, OR INDIRECT, SPECIAL, CONSEQUENTIAL OR INCIDENTAL DAMAGES OF ANY KIND AS A RESULT OF THE USE OF THE PRODUCTS MANUFACTURED BY SELLER, WHETHER USED IN ACCORDANCE WITH THE INSTRUCTIONS OR NOT. UNDER NO CIRCUMSTANCES SHALL SELLER'S LIABILITY TO BUYER EXCEED THE ACTUAL SALES PRICE OF THE VSAT PRODUCTS HEREUNDER.

In some jurisdictions, Buyer may have other rights under certain statutes that may imply non-excludable warranties. No representative is authorized to assume for Seller any other liability in connection with the VSAT products.



DO NOT DISCARD CONTENTS

The product in this packaging was placed in the market after August 13, 2005. Its components must not be discarded with normal municipal or household waste.

Contact your local waste disposal agency for recovery, recycling, or disposal instructions.